



Model Number

NBN4-F25-2Z4L-V1

Features

- Direct mounting on standard actuators
- Small construction with sturdy plastic housing of protection class IP 67
- 2-wire DC sensor with minimum off-state current
- M12 male connector

Accessories

BT32

Activator for F25 series

BT33

Activator for F25 series

BT34

Activator for F25 series

BT32XAS

Activator for F25 series

BT43-RG-01

Activator for F25 series including protective housing and mounting plate

Technical Data

General specifications

Switching function		2 x normally open (NO)
Output type		Two-wire
Rated operating distance	s_n	4 mm
Installation		flush mountable
Output polarity		DC
Assured operating distance	s_a	0 ... 3.24 mm
Actual operating distance	s_r	3.6 ... 4.4 mm typ.
Reduction factor r_{Al}		0.6
Reduction factor r_{Cu}		0.45
Reduction factor r_{304}		1
Reduction factor r_{St37}		1.2
Output type		2x 2-wire

Nominal ratings

Operating voltage	U_B	5 ... 30 V DC
Switching frequency	f	0 ... 500 Hz
Hysteresis	H	typ. 5 %
Reverse polarity protection		reverse polarity protected
Short-circuit protection		pulsing
Voltage drop	U_d	≤ 4.5 V
Design data		
Operating current	I_L	4 ... 100 mA
Off-state current	I_r	120 ... 200 μ A typ. 175 μ A at 25 °C
Time delay before availability	t_v	≤ 100 ms
Switching state indicator		LED, yellow

Ambient conditions

Ambient temperature	-25 ... 70 °C (-13 ... 158 °F)
Storage temperature	-40 ... 85 °C (-40 ... 185 °F)

Mechanical specifications

Connection type	Connector plug M12 x 1, 4-pin
Connector housing	metal
Housing material	PBT
Sensing face	PC
Degree of protection	IP67
Mass	49 g
Tightening torque, fastening screws	M5 x 25 : 2.7 Nm
Note	Mounted on mechanical drive

Compliance with standards and directives

Standard conformity	
Standards	EN 60947-5-2:2007 EN 60947-5-2/A1:2012 IEC 60947-5-2:2007 IEC 60947-5-2 AMD 1:2012

Approvals and certificates

UL approval	cULus Listed
CCC approval	CCC approval / marking not required for products rated ≤ 36 V

Dimensions

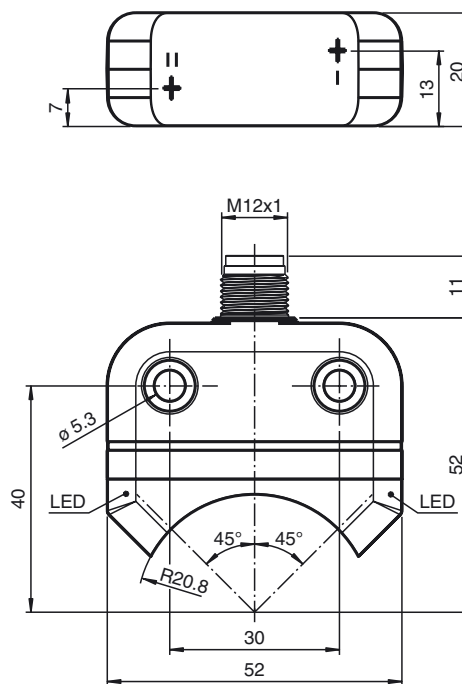

Electrical Connection

